



**ContraFlame® JF30 System
Application Procedure For Chevron Future Growth
TCO Project (P6061)**

Document Ref:	7577-1505
Issue No:	01
Date:	15/05/2018
Prepared by:	Ritchie Warden
Approved by:	Steve Bonell

Index

1	Purpose of Document	3
2	Health & Safety	3
3	Quality Assurance/Quality Control	4
4	Ambient Conditions	5
5	Application of Approved Protective coating System	7
6	Application of the Tie coat	8
7	Application of ContraFlame® C50 X8 Foam.	9
8	Terminations	12
9	Application of the JF30 D2004 Laminate System	23
10	Repair Procedure	26
11	Reinstatement of JF30	27
12	Housekeeping and Waste Disposal	28
13	Tools and Equipment	30
14	List of Test Equipment	31
15	Appendices	31

1 Purpose of Document

This document sets out how to apply ContraFlame® JF30 system to the inside and outside of vessel skirts. The areas and its system to be applied can be found in AIS document 7577-1511.

Please note that this application procedure is only able to detail application for areas, locations and features which have been identified by DSME on the drawings. Where application is required which is not detailed in this procedure, then it is because AIS have never been made aware of the requirement or been issued with any drawings. For these new areas, AIS will propose a solution and update the application procedure. Please note that the AIS Site Manager has the full support to propose a solution and execute application prior to the application procedure being updated, if there is urgency to complete insulation to the desired area.

Please note that for all application listed in this procedure, the AIS Site Manager has the discretion to deviate for installation areas where he considers the installation will be stronger and have improved integrity.

2 Health & Safety

It is the policy of Advanced Insulation Ltd (Company) to conduct all activities in a safe manner in accordance with defined procedures and utilising staff adequately trained in all aspects of the work.

Site Supervisors are issued with a Site Safety Manual that documents Company safety policy and procedures, risk and COSHH assessments and first aid/emergency instructions.

Site Supervisors must instruct all applicators on the Health & Safety expectations of the Company and any other aspect of Company policy through regular toolbox talks.

There will be activities which require segregation from other site activities and this will be achieved utilising appropriate barriers and signage.

Throughout this procedure reference is made to the control measures and level of personal protective equipment (PPE) required for the activities being conducted. All staff must comply strictly with these requirements. A list of PPE is provided below.

An eye wash dispenser will be located in the work zone adjacent to the planetary mixers.

2.1 Personal Protective Equipment

Face Protection

Half face Respirators 3M 7500 Series with 6057, 5935 filters & 501 retainer

Full Face Mask 3M 6000 series with 6057, 5925 filters and 501 retainer

Chemical splash goggles (for use when working underneath equipment)

Safety Glasses with side shields

Eye Wash Dispenser

Hand and Arm Protection

Nitrile Synthetic Rubber Glove EN374-3 (these gloves offer a chemical protection for up to 480 minutes except when exposed to Acetone)

LPF Finex Disposable Latex Gloves EN374-3 – for use with Acetone (can be worn on top of Nitrile)

Cotton inner sleeves

Polythene sleeve covers

White Cotton inner gloves

Rigger style gloves

Skin/Body Protection

Barrier/Pre-work Cream

3M Disposable Coveralls (4540+) or equivalent breathable chemical resistant coveralls with hood

Ty-Chem C coverall when working underneath equipment

Footwear

Safety Boots

Head Protection

Hard Hats

The prescribed Company standard of hygiene and working practice must be maintained to avoid allergic reactions to the skin. Sensitisation of the skin can be caused by certain materials as detailed in the Safety Data Sheets and substance identification records provided in the Site Safety Manual.

Where client HSE requirements, including but not limited to PPE, exceed those stated in this document, the client requirements shall be followed.

3 Quality Assurance/Quality Control

Control of the quality of applied ContraFlame® subsea insulation material is crucial in order to achieve the consistent thermal insulation performance expected by our clients. Material testing is conducted during manufacture of all ContraFlame® components and it is important that this level of control extends to the application process.

Client equipment must be protected prior to application commencement. Care and attention shall be taken to ensure all areas not requiring insulation are not contaminated. Access and egress to application areas shall be assessed in order to prevent inadvertent damage to client equipment.

The respective inspection and test plan document 7577-1502, shall be used for each project to determine the agreed test and inspection criteria.

Ambient conditions as defined in Section 3 will be measured a minimum of four times (equally spaced) during a shift or upon sudden changes in the weather conditions as may be experienced in tropical

climates. Results will be entered onto the Daily Inspection Report along with material batch numbers used, details of equipment coated, and stage of completion.

Consistency of mixed and applied material must be maintained by following the detailed procedure as outlined in Sections 4 to 7 below. Fireproofing/Insulation performance relies mostly on the C50 X8 foam layer being maintained within its stated parameters.

4 Ambient Conditions

4.1 Temperature

All ContraFlame® materials are based on two component parts, parts A and B. The cure mechanism is accelerated by the catalyst (Part B) being added, polymerisation of the base resin matrix (Part A) will commence.

The speed of this polymerisation reaction is temperature related, the optimum temperature for application work is between 15°C and 40°C, and account must be taken of temperatures above and below those recommended to ensure that adequate cure takes place within the expected timescales.

4.2 Humidity

ContraFlame® materials are designed to be moisture resistant, however during application and cure an amount of water vapour is emitted from the material. It is important therefore, that the temperature of the surfaces to be coated shall be at least 3°C above the dew point, and the relative humidity shall be less than 90%.

The ambient conditions will be measured using electronic, digital or manual equipment. Readings must be taken daily prior to work commencing and every three hours thereafter, thus resulting in a minimum of four readings per shift (see section 2). Results must be recorded on the Daily Inspection Report.

Where conditions fall outside of those stated above, appropriate action must be taken to rectify this either by modification to site environmental conditions, provision of sheeting and local microclimate (heaters/chillers/air blowers etc.) or by modification to the stated application/over-coating times with a potential impact on productivity.

4.3 Air Quality

When working in confined spaces, good ventilation and extraction will be necessary. It is generally accepted that not less than six air changes per hour will be sufficient to provide adequate air quality.

4.4 Surface Preparation

It is important that all surfaces to be coated are in a clean condition before application begins. It is the client's responsibility to provide clean uncontaminated equipment and where contamination is

deemed excessive the equipment shall be rejected. Where small levels of oil or grease contamination are present, a suitable degreasing procedure must be carried out as follows: Using a clean, dry, lint free cotton or polyester cloth moistened with solvent, wipe the whole surface of the structure to be insulated taking care to remove the contamination by frequent turning of the cloth. Approved solvent cleaners are either Acetone, Industrial Methylated Spirits (IMS) or Methyl Ethyl Ketone (MEK) all of which must be in a virgin format. If these solvents cannot be sourced then approval must be given by AI Technical and H & S before an alternative is used. Care must be taken not to re-contaminate or spread contamination through the use of soiled rags. Suitable gloves must be worn when handling solvents. Disposable Latex gloves EN374-3 provide adequate protection against solvents. More than one pair can be worn at once to provide added protection.

It is important that surfaces to be coated are maintained in a clean condition and where the environment is likely to cause contamination in either the mixing, tile forming or application processes such as in a particularly dusty area, or where rain or spray or other contaminants may be present, or where there may be other trades working nearby (painting, welding, shot blasting etc.), the immediate area must be isolated by sheeting sufficient to prevent the ingress of contaminants.

Client supplied drawings shall be checked prior to application to determine the location, diameter and quantity of PVC plastic inserts for vent and grease ports. All flanged connections shall have breather tubes fitted where specified, and hydraulic control lines on applicable equipment shall be protected to avoid any damage.

Pedestrian and vehicular traffic must be kept to a minimum within the working area.

The work area should be cordoned off utilising rope or tape with no entry boards attached to ensure that other trades are kept from entering the work zone. It is essential that all working areas are kept clean to prevent contamination of the substrate and insulation material as detailed above.

4.5 Material Storage and Shelf Life

The materials should be stored in cool conditions out of direct sunlight and in closed containers. ContraFlame Part A components will slowly harden with time and the shelf life is directly proportional to the storage temperature. At a constant 5°C the shelf life is 6 months minimum, storage below 5°C could result in an extended shelf life(subject to revalidation process)At an ambient temperature of 20°C or below the shelf life will be 2 months minimum, storage above 20°C will result in shortened shelf life and is to be avoided.

The shelf life for the Part “B” components is 18 months when stored at ambient temperatures of 20°C.

Refrigerated containers will be used for transportation and storage on site and the temperature of these containers shall be set to achieve an average air temperature of 5°C or less. Short term cycling of the air temperature in the container will occur due to thermostat switching and this will result in a temperature variation of no more than 2 or 3°C. Periodic opening of the container doors may cause larger fluctuations in the air temperature, however, the effect on the material temperature will be minimal due to the time lag in temperature change of materials stored in bulk and hence shelf life will be virtually unaffected. It is important that doors are kept tightly closed when not in use.

Data loggers are placed in all refrigerated shipping containers and these should be examined on receipt at site to ascertain the storage temperature history of the shipment. Data loggers are also

placed in site storage containers and these should be examined weekly to determine that the container performance is to specification. In the event that temperature control is found to have been poorly maintained, for example where power outage has occurred, the total accumulated excursions above the specified storage temperature will be assessed to estimate whether the shelf life may have been shortened. Where there is reasonable cause to suspect that this is the case then the material in question will be inspected for signs of discolouration and hardening; where this is evident then a practical assessment will be made by mixing/application trials conducted according to procedure for D2004 laminate and a decision on the suitability for use will be made by the site manager or supervisor.

5 Application of Approved Protective coating System

Prior to the application of the ContraFlame® Fireproofing system, the substrate shall be coated with an epoxy modified phenolic/epoxy based paint system which has been qualified to (or the equivalent of) **NORSOK MCR-501**

ContraFlame® shall not be applied directly to coatings that contain iron oxide pigment.

ContraFlame® shall not be applied directly over thermally sprayed aluminium.

The selected protective coating system shall be applied as in accordance with the Paint Manufacturer's recommendations and the Client's Painting Specification.

After application of Project/Advanced Insulation approved corrosion protection coating system, and prior to application of ContraFlame® materials, all surfaces must be visually inspected for paint defects (mechanical damage) and any localised areas of oil or grease contamination.

The protective coating system shall be applied to a minimum thickness of 200µm and be suitable for use under fireproofing and insulation at the specified operating temperatures of the project. The completed coating system shall be holiday free.

Listed below are examples of approved protective coating systems that have been specified for the external protection of Oil & Gas Processing Vessels, miscellaneous Piping and Riser Pipes with high operating temperatures:

- Sigma: Sigmadur 540
- Akzo Nobel: Interbond 2340

Listed below are examples of approved protective coating systems that have been specified for the external protection of I Tubes, Riser Pipes, vessel saddles, Cellar deck structures:

- Akzo Nobel: Interthane 990

Other Protective Coating selections are welcomed and can be submitted for approval by the client and Advanced Insulation.

6 Application of the Tie coat

ContraFlame® Tie Coat consists of a thixotropic, formulated phenolic resin compound and is used to ensure good wetting of the coated steel surface and to aid adhesion during application and service.

It is supplied in two pre-weighed containers; do not divide the pre-dispensed units. The Part A (the larger container 0.45kg) is a dark brown colour; Part B is a (yellow/brown liquid 0.06kg).

6.1 PPE Requirements for Tie coat

Tie Coat is a two part viscous liquid. In accordance with AI COSHH assessment, safety glasses suitable for chemical use, Nitrile synthetic rubber gloves and 3M Disposable Coveralls (4540+) or equivalent with hoods. However, where a risk of dripping from the substrate i.e. underneath equipment, a TYCHEM C (yellow) chemical coverall with hood shall be worn.

6.2 Surface Inspection / Preparation

Before any application of tie-coat to the painted surface, an inspection of the surface must be conducted. All damage found must be repaired using a suitable/compatible paint system. All repairs to coatings shall be carried out in accordance with the Paint Manufacturer's and client's own repair procedure.

6.2.1 Any mechanical damage found and subsequent repairs shall be recorded in the AI Daily Inspection Report for JF30.

6.2.2 The Protective Coating system shall be abraded with a grade 80 sand paper to provide a good mechanical key prior to the application of the tie coat.

This shall be followed by a solvent wash to ensure that the surface is free of dirt and dust, inspect prepared surfaces in accordance with LP02-E16.

6.3 Application of Tie-coat

6.3.1 Verify the ambient conditions are in accordance with those prescribed in Section 3. The ambient conditions shall be recorded in the daily inspection report. No application shall be started if ambient conditions are outside the prescribed range.

6.3.2 Verify that the Tie-Coat components are within the stated shelf life by checking the manufactured date on the batch label and that the material is in good condition in accordance with Section 3.5. Record the batch details in the daily inspection report.

6.3.3 Add the entire contents of the Part B container to the Part A container and mix thoroughly until the mixture has achieved a uniform colour.

6.3.4 Tie Coat shall be applied by brush or roller to an area which may be conveniently over-coated with ContraFlame® C50 X8 within the over-coating window. Tie Coat shall be applied at a moderate wet film thickness (150 to 300 microns) and this must be checked using a suitable wet film thickness gauge. The range of results is recorded on the daily inspection report.

- 6.3.5 Tie Coat must be left until the correct degree of tack has been achieved in order that the foam layer bonds adequately to the primer. The ideal level of tack is such that the resin is no longer liquid and mobile but that there is a significant degree of pluck when touched lightly with a gloved finger. If the finger is easy to remove with little or no effort then the tie coat is too dry and must be over-coated.
- 6.3.6 Tie Coat cure is temperature and humidity dependent and the ideal level of tack may be achieved in 15 to 60 minutes. To avoid excessive tack off times, temperatures below 15°C shall be avoided through the use of tenting and warm air blowers. In the event of tenting being required, the enclosure must be suitably ventilated. Temperatures above 20°C will give reduced time to tack and a narrower over-coating window as will very low humidity levels. Conversely, high humidity levels (up to 75-90% RH) will extend tack times. In any case the guidelines for the optimal tack level detailed above are still valid.
- 6.3.7 The maximum over-coating time is 2 hours after the tacky stage has been reached. In the event that the maximum over-coating time is exceeded then a further coat of tie coat must be applied.
- 6.3.8 Where full cure has taken place, the surface must be abraded using 80 grade sandpaper, dust must be removed using clean solvent then fresh tie-coat can be applied as per 6.3 procedure.

7 Application of ContraFlame® C50 X8 Foam.

ContraFlame C50 X8 consists of a formulated phenolic resin syntactic foam. It is supplied in a kit comprising of two pre-weighed packages; do not divide the pre-dispensed units.

Part A (8.5kg) a buff coloured paste supplied in a heat-sealed 500 gauge polythene bag.

Part B (2kg) a yellow / brown liquid supplied in a 2.5ltr plastic container.

7.1 PPE Requirements for Application of Foam

C50 X8 Foam is a two part paste and therefore, in accordance with COSHH assessment, safety glasses suitable for chemical use, Nitrile Synthetic Rubber Gloves and 3M 4540+ coveralls with hoods must be worn.

7.2 Mixing

- 7.2.1 Verify that the ambient conditions are in accordance with those prescribed in Section 3. The ambient conditions shall be recorded in the daily inspection report. No application shall be started if ambient conditions are outside the prescribed range.

- 7.2.2 Verify that the C50 X8 components are within the stated shelf life by checking the manufactured date on the batch label and that the material is in good condition in accordance with procedure. Record the batch details in the daily inspection report.
- 7.2.3 Mixing shall be carried out in a planetary (or similar) dough mixer. Mix or shake Part B thoroughly Add Part A to the mixing bowl and mix at lowest speed. Add the contents of the Part B container, and then continue mixing operation until the resultant paste has changed to a uniform light yellow colour and no buff traces remain. It will be necessary to stop the mixer and scrape the blade and sides of the bowl at least once during the mixing cycle to ensure that no traces of un-mixed material remain.
- 7.2.4 The pot life of the mixed material is proportional to the application temperature. It is important that the material is used within the time period of approximately 60 minutes, particularly where ambient temperatures are at the extremes of those stated in Section 3.
- 7.2.5 During the application of the C50 X8 Foam, the best results can be achieved by firstly kneading the material between your gloved hands and then shaping the material foam into a slab at a thickness in excess of the specified 10-15mm. Apply the slab onto the primed steel substrate and commence tamping with a plastic trowel to compress the material onto the substrate and subsequently achieve the correct thickness specified by the smoothing and tamping action.
- 7.2.6 An alternative method of preparing slabs is to press the C50 X8 material into a rectangular frame of a specified thickness, then when fully consolidated remove the frame and cut the slabs to size.
- 7.2.7 For piping spools the application thickness shall be controlled by using a metric needle gauge, or thickness guide half shell rings (Manufactured C50 X8 composite rings to the specified thickness). The C50 X8 composite half shells shall be bonded to the substrate with tie coat and becomes part of the Fireproofing system.
- 7.2.8 It is also good practice to utilise a flexible hose thickness guide when applying ContraFlame® to Process Vessels. In addition, applying several thickness guide slabs in random locations when working large areas will ensure uniformity of thickness.
- 7.2.9 Thickness Inspection Ports (20mm diameter) can also be inserted into the applied foam for verification of the Fireproofing thickness; the spacing of the thickness inspection ports shall be nominally 1 per m².

Film Thickness

ContraFlame® C50 X8 foam applied thickness shall be 10 -15mm, this is dependent on the required Fireproofing rating and either thickness is achievable in a single coat application.

During application, the wet film thickness should be monitored using metric thickness gauges or by one of the suitable thickness guides listed above.

ContraFlame® C50 X8 does not shrink volumetrically during cure; therefore the wet film thickness will equal the dry film thickness.

- 7.2.10 Water, solvent or other agent must not be used to thin the C50 X8. However, it is permissible to use water for the continuous cleaning of the plastic float and other tools, excess water should be shaken off floats prior to reuse.
- 7.2.11 It is important to ensure that the material is firmly pressed into edges and corners.
- 7.2.12 Ensure that the applied C50 X8 Foam is finished with a smooth even surface to accept the D2004 laminate system. Imperfections such as hairline joint markings are acceptable, but voids and gaps must be made good to achieve a uniform and smooth finish.
- 7.2.13 Where there is a permanent termination of the ContraFlame system, the D2004 laminate must be bonded directly to the primed steel substrate. To accommodate this, the C50 X8 foam layer shall be tapered down to the painted steel substrate at an angle of between 30 and 45 degrees as shown below for ease of laminating the termination point.

TERMINATION POINT

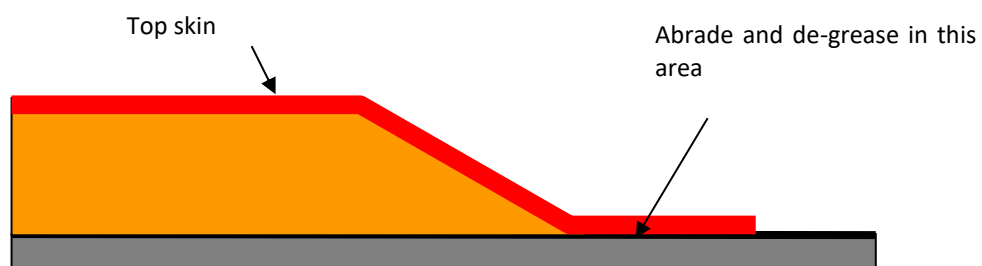

7.3 Over coating Times

Prior to over coating, the ContraFlame® C50 X8 should preferably be left to cure for a period of **48 hours** although with ambient temperatures of at least 20°C, a minimum period of **24 hours** is acceptable. The over coating time is related to the environmental condition during both application and cure. Advanced Insulation should be approached to offer specific advice where the application conditions differ from those specified.

8 Terminations

This section of the procedure details how to terminate the ContraFlame® JF30 system to various features on the Vessel body and skirts.

8.1 Vessel anchor chairs

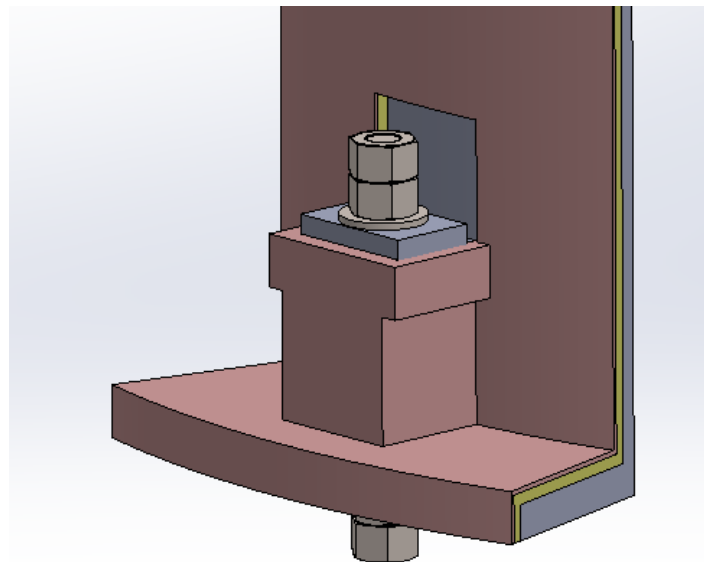

The above picture shows a typical termination of the ContraFlame® JF30 system to vessel anchor chairs.

A fabricate fitted D2004 laminated plate to cover the open end of the vessel anchor chair (exposed bolt) and then apply with C50 on top of that up to the chair top. The termination is to be up to the side of the anchor chair and on the skirt finishing above and below where the bolt nuts finish. This is to allow specific tooling to untighten the bolts if required. It is at the AIS site manger discretion of where the ContraFlame® will terminate to allow sufficient access to the bolt nuts.

Where the geometry prohibits the application of ContraFlame® JF30 (restricted corners) AIS may choose to use ContraFlame® C20 thixotropic as an alternative.

8.2 Skirt Supports under 185°C

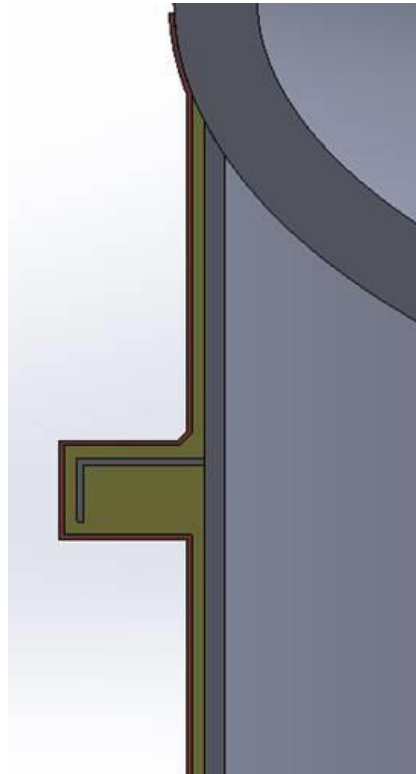

The above picture shows a typical termination of the ContraFlame® JF30 system to steel supports located on the skirts.

ContraFlame® C50 material shall full encapsulate the skirt support. The D2004 laminate system shall fully encapsulate the ContraFlame® C50 material and terminate on the vessel body.

8.3 Vessel Anchor Bolt Masking

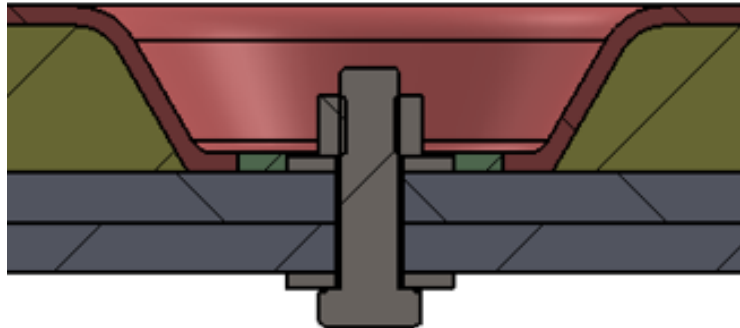

The above picture shows a typical termination of the ContraFlame® JF30 system to vessel anchor bolts.

TCO have advised that there will only be a maximum of 10mm gap between the edge of the largest washer to where the ContraFlame® JF30 system terminates. At the point of intersect of the ContraFlame® material this will be transitioned down as a steep slope at the discretion of the AIS site manager. The D2004 laminate system will then follow the profile of the material and terminate to maintain the 10mm gap required.

The termination of the ContraFlame® JF30 system will be sealed using ContraFLame® C20 Thixotropic material.

8.4 Inside and outside skirt on all vessels above 185°C

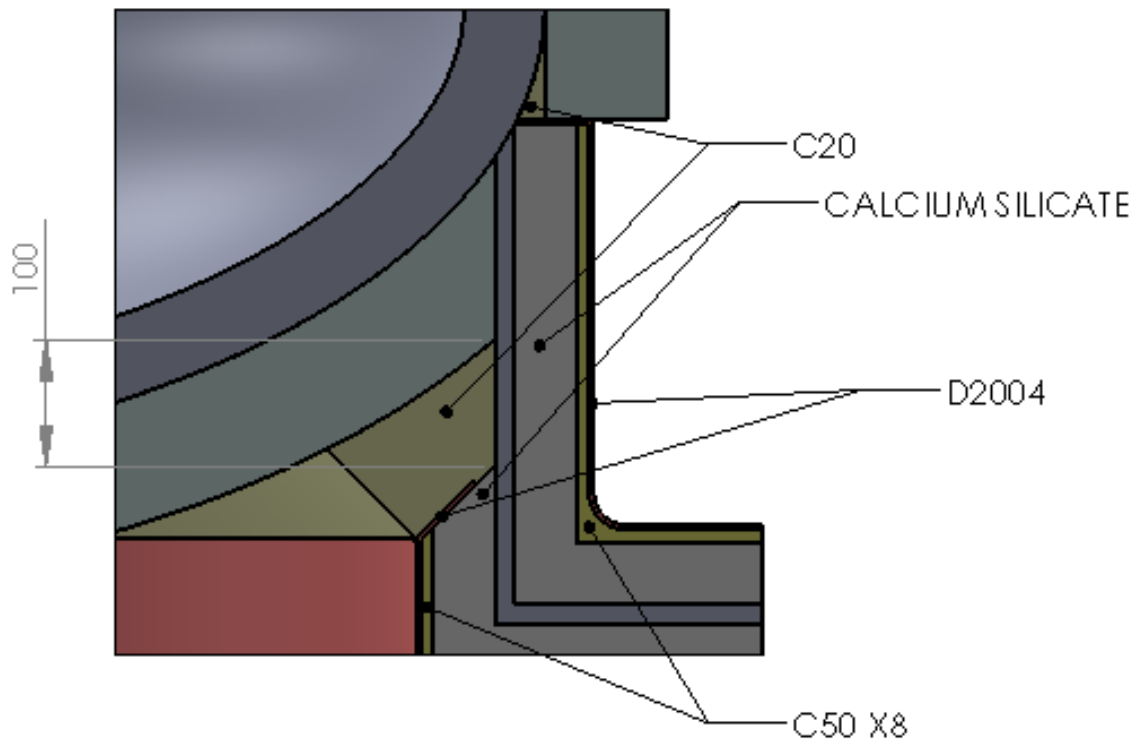

The above picture shows a typical termination of the ContraFlame® JF30 system to the inside and outside of the skirts on a hot vessel.

Calcium silicate insulation is to be installed to surfaces of the vessel inside and outside the skirt. After AIS internal analysis, calcium silicate is not required on the entire skirt surfaces. Calcium silicate will be applied from the top of the skirt and finish 300mm down from the intersection of the skirt and vessel body. ContraFlame® JF30 system is to be applied directly on top of the calcium silicate insulation and terminated onto the calcium silicate. D2004 laminate system is not to be applied directly to the surface of the vessel. Apply suitable radius into all external and internal corners to allow a smooth transition of the D2004 laminate system around the skirt and vessel.

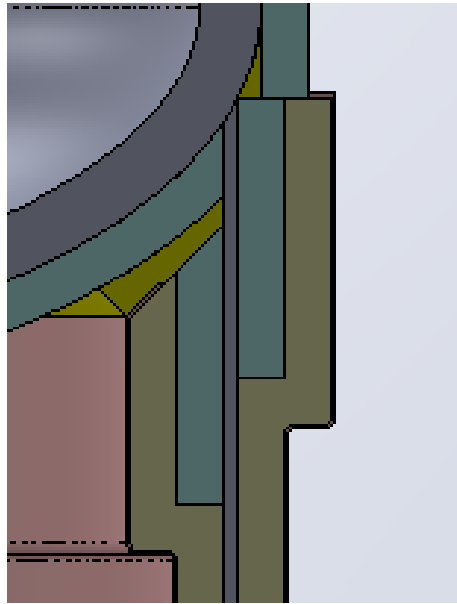

The above drawing illustrates the termination of the Calcium silicate. This is a typical view showing the ContraFlame® material on top of the calcium silicate for J30 10mm thick C50 and for H120 50mm thick. The above image shows 50mm thick C50.

8.5 Inside skirt on all vessels below 185°C

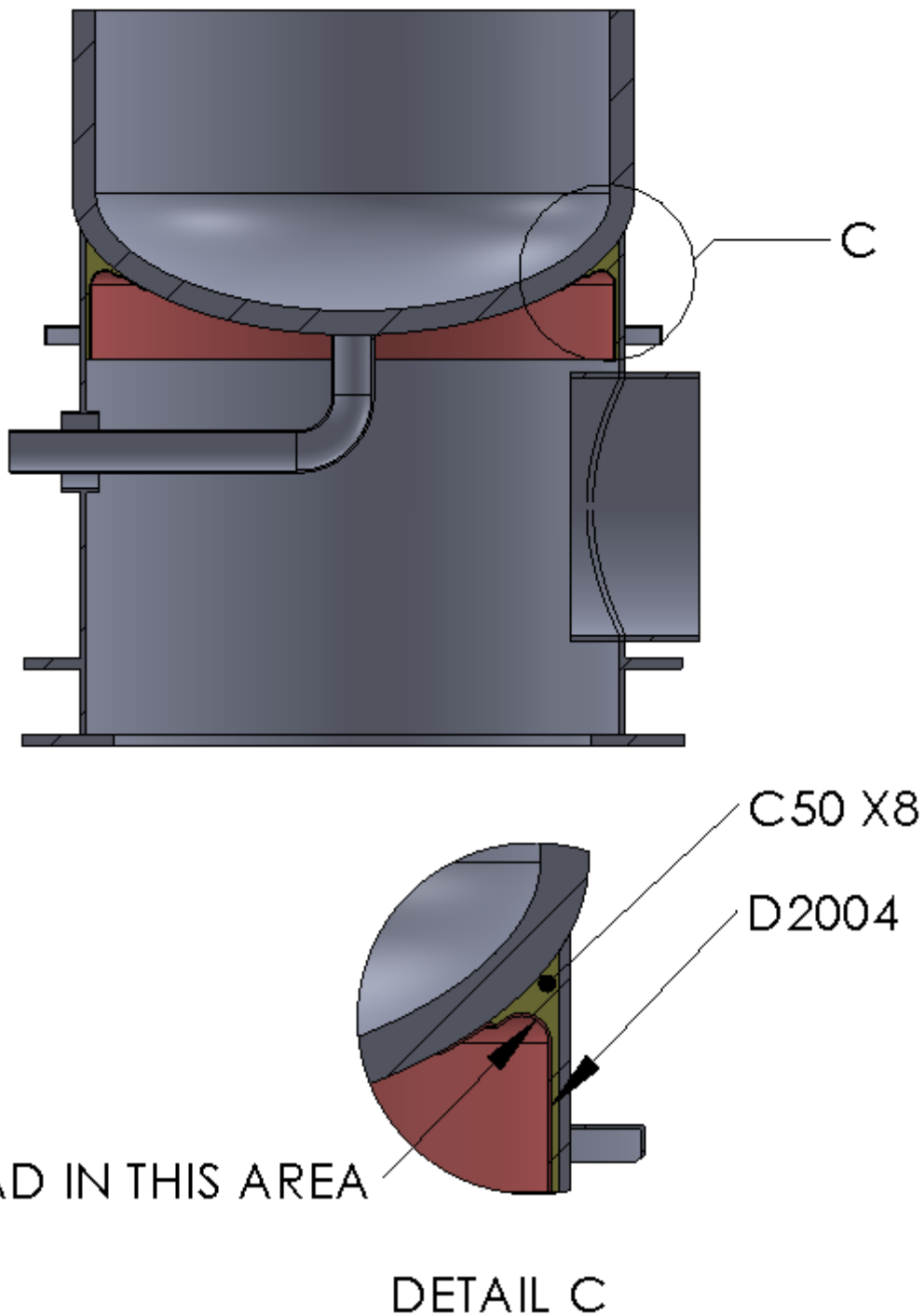

The above picture shows a typical termination of the ContraFlame® JF30 system to the inside of the skirts on a cold vessel.

Due to the fire requirement on a vessel below 185°C, ContraFlame® JF30 system is not applicable on the vessel surface which is located inside the skirt. Apply suitable radius into all external and internal corners to allow a smooth transition of the D2004 laminate system around the skirt and vessel. The

internal corners of the skirt and vessel under body will be packed with C50 material with a suitable radius. This will allow a smooth transition of the D2004 laminate system which will come onto the vessel body at the AIS site managers discretion to ensure the system is terminated appropriately.

If Insulation has been applied to the vessel body inside the skirt then the termination of the Contraflame® JF30 system will be as per below image.

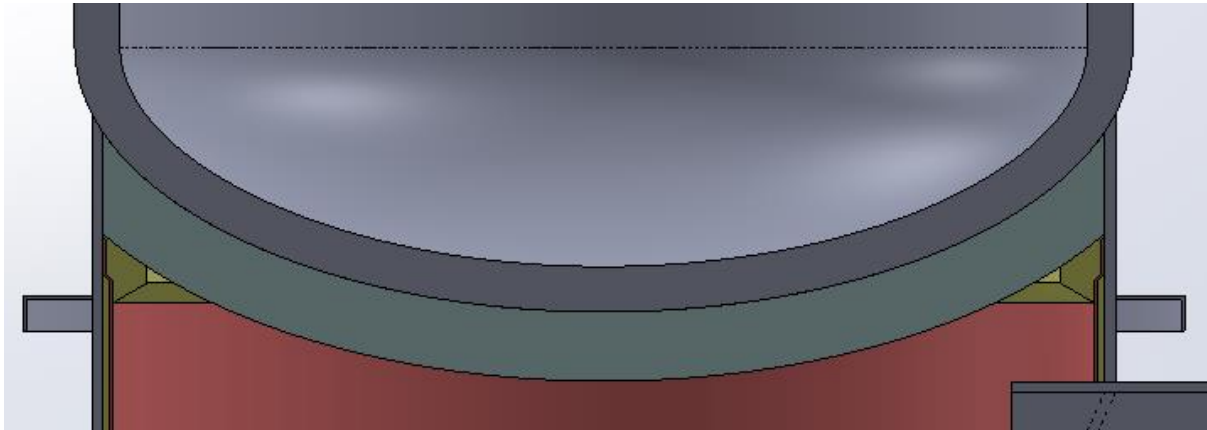

ContraFlame C20 material will be used to fill the void between the termination of the ContraFlame® JF30 system and Insulation.

ContraFlame® C20 material is easily removable by excavating the material away from the surface. For reinstatement after maintenance, AIS Site Managers must supervise the material being re applied as it requires a 2km machine to successfully mix and then re instate the material.

8.6 vessel skirt access opening

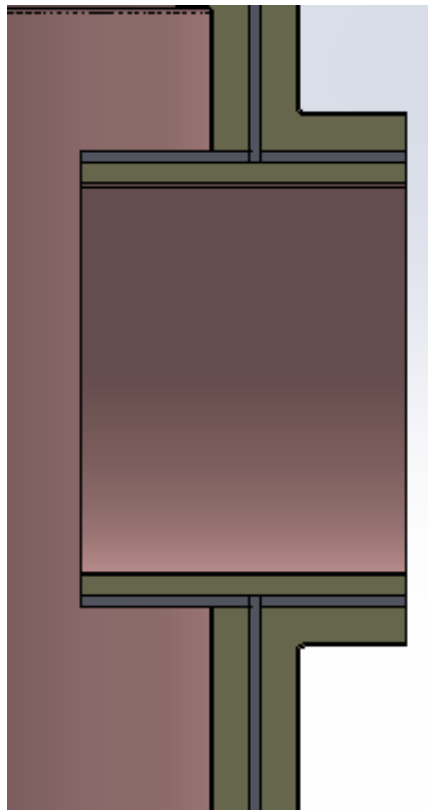

The above image illustrates the typical application to a access hole which is located on the vessel skirts.

DSME have advised that the access hole needs to be a minimum of 535mm internal diameter. The access hole is 600mm which will cause a reduction of material thickness for the ContraFlame® H120 system.

For J30 fire protection the internal surface will consist of 10-15mm thick C50 plus 4mm of D2004 laminate.

For H120 fire protection the internal surface will consist of 20-25mm thick C50 plus 4mm of D2004 laminate. This does not meet H120 certification and will carry no warranty in this area.

8.7 Horizontal vessel saddle termination

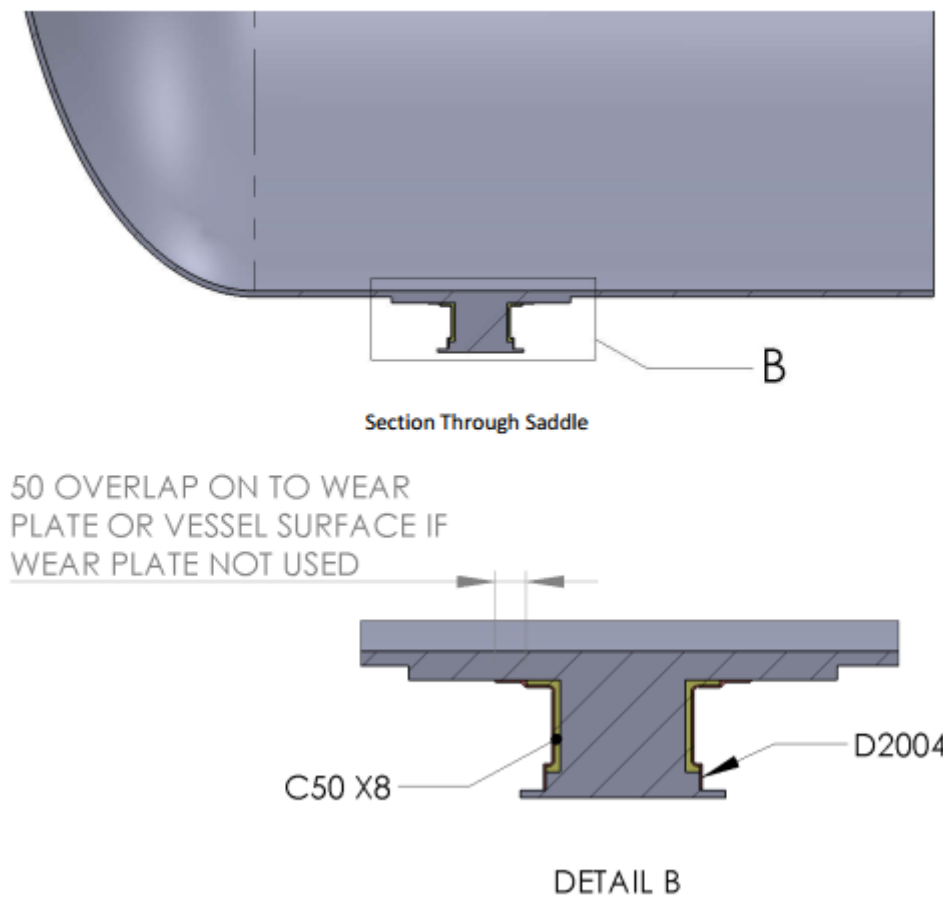

The above picture shows a typical termination of the ContraFlame® JF30 system to saddles on a horizontal vessel.

ContraFlame® C50 material shall be applied around the saddle and terminated onto the horizontal surfaces of the saddle. Ensure there is a suitable radius or chamfer to allow a smooth transition and termination of the D2004 laminate system onto the saddle surface. Apply ContraFlame® C20 Thixotropic over the complete system termination.

8.8 Tailing Lug

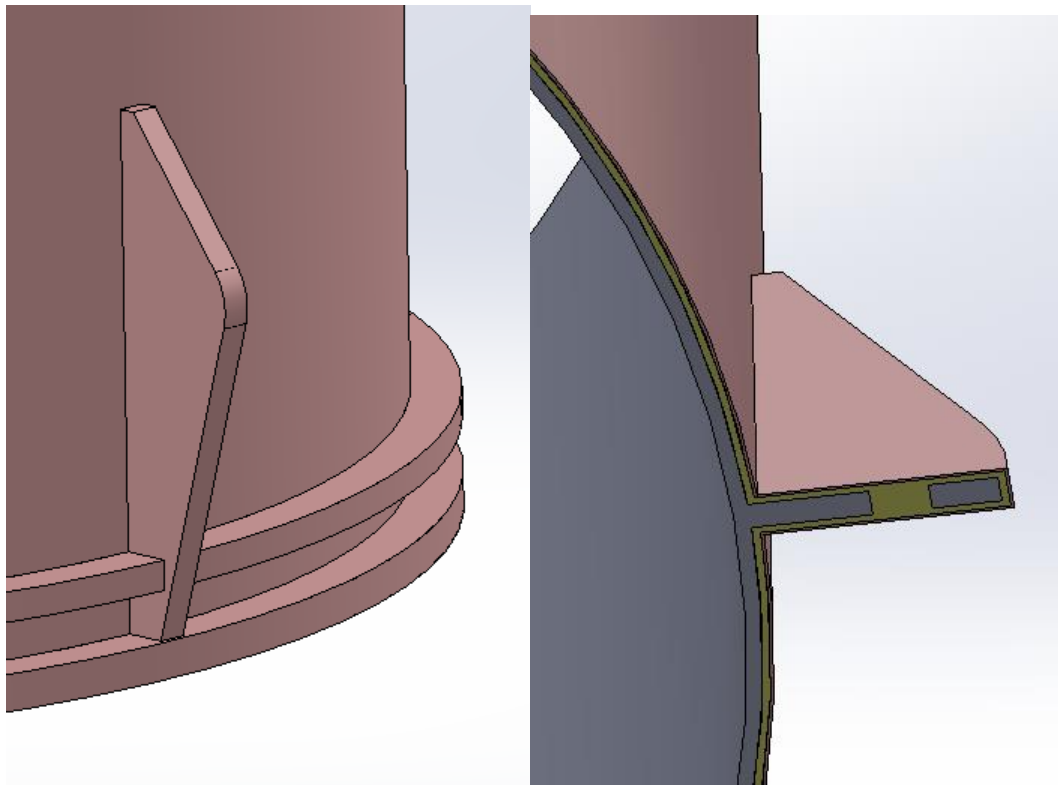

The above picture shows a typical termination of the ContraFlame® JF30 system to tailing lugs.

ContraFlame® C50 material shall be applied around the tailing lug and fully encapsulate the tailing lug hole. Ensure there is a suitable radius or chamfer to allow a smooth transition of the D2004 laminate system around the tailing lug surface.

8.9 Saddles for horizontal vessels with ContraFlex jackets over the bolted area including sliding end horizontal vessel saddle

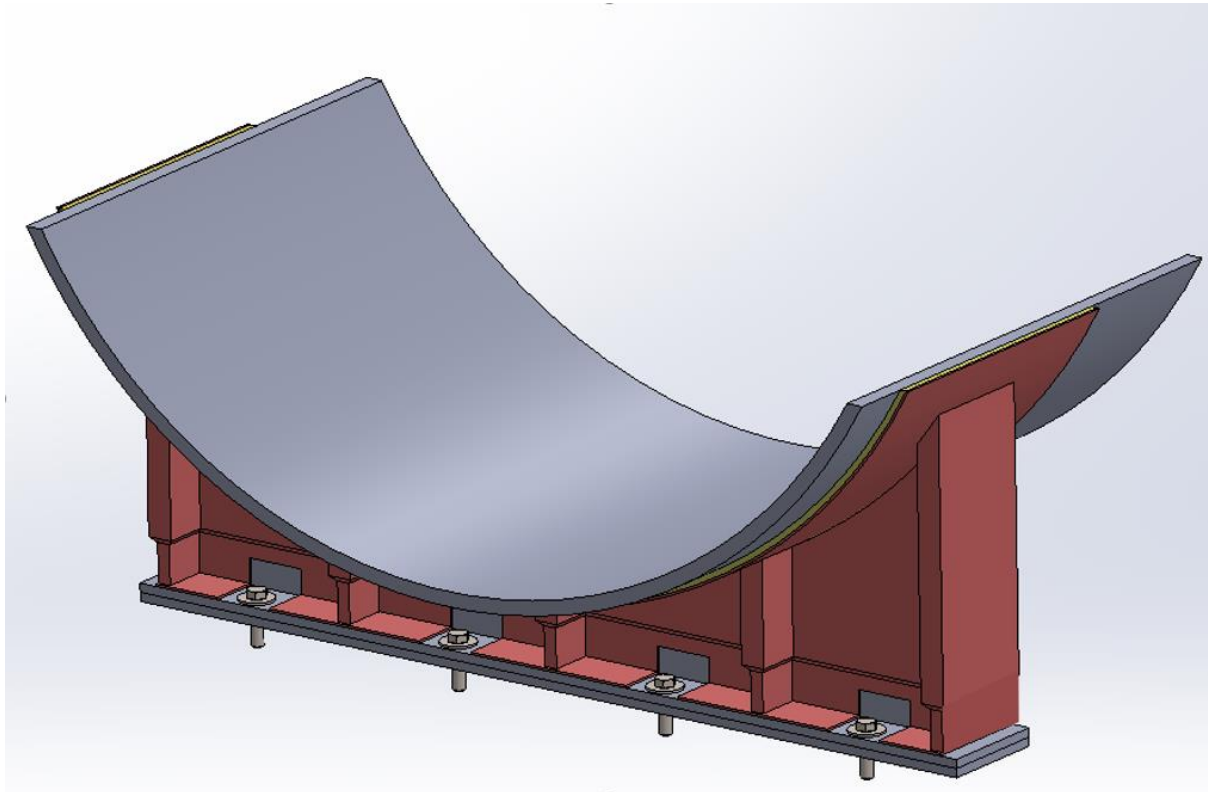

The above picture shows a typical termination of the ContraFlame® JF30 system to saddles on horizontal vessels.

ContraFlame® C50 material shall be applied around the stiffeners of the saddle to fully encapsulate the saddle. The D2004 laminate system will terminate just short of the bolts to ensure access to release the bolts if required. Ensure there is a suitable radius or chamfer to allow a smooth transition and termination of the D2004 laminate system onto the saddle surface.

Please Note:

A reduced thickness of ContraFlmae® JF30 system will be applied if necessary around the bolt location to allow access.

Please Note:

All areas covered in this procedure meet the J30 fire protection requirement unless otherwise stated.

Please Note:

It shall be at the AIS site manager's discretion to use their own judgment on whether to install to these methods as detailed in this procedure or if they see a more viable or efficient alternative installation method which would achieve the same installation requirements, they are permitted to use this. They are required to liaise with AIS project team for any guidance if required.

9 Application of the JF30 D2004 Laminate System

Conduct a visual inspection of the C50 X8 surface to ensure that a uniform smooth surface has been achieved and there are no projections, voids or other imperfections.

Ensure that the C50 X8 substrate is clean and dust free prior to application of D2004 laminate system.

The D2004 Laminate system consists of a combination of 2 layers of 450g/m² Chopped Strand Mat and a 2 layers of 450g/m² Biaxial woven cloth impregnated with the D2004 Phenolic resin, followed by a resin flow coat to provide a resin rich protective and aesthetic finish.

9.1 D2004 Resin Laminate system

The D2004 resin and catalyst are supplied in bulk form for subsequent decanting at the application site.

Part A resin supplied in 200kg metal drums or 25kg plastic drums.

Part B catalyst supplied in 2kg plastic containers.

Glass fibre reinforcement: 450g/m² 600g/m² is supplied in 45-50kg rolls.

9.2 PPE Requirements for application of D2004 Laminate System

D2004 laminating resin is a two part phenolic and therefore, in accordance with COSHH assessment, safety glasses suitable for chemical use, Nitrile Synthetic Rubber gloves and 3M Disposable Coveralls (4540+) or equivalent with hood must be worn for general application. However where a risk of dripping from the substrate i.e. underneath equipment a TYCHEM C (yellow) chemical coverall with hood shall be worn. Measures must be taken to protect applicators skin from contamination from material dripping onto the skin especially the head, face and neck areas.

9.3 Mixing

- 9.3.1 Verify the ambient conditions are in accordance with those prescribed in Section 3. The ambient conditions shall be recorded in the daily inspection report. No application shall be started if ambient conditions are outside the prescribed range.
- 9.3.2 Verify that the D2004 components are within the stated shelf life by checking the manufactured date on the batch label and that the material is in good condition in accordance with 3.5. Record the batch details in the daily inspection report.
- 9.3.3 Using calibrated scales measure 1 - 2 kg of D2004 Part A into a suitable container (plastic bucket), this is sufficient to coat 0.25 -0.5m², add Part B at a rate of 10% by weight.
- 9.3.4 The part B (Amcat 3) shall be decanted into the plastic graduated bottle for ease of dispensing. The quantity to be added will be between the values given above measured by weight; the dispensed volumes shown in the table below have been worked out according to the material densities.
- 9.3.5 The pot life of a mixed container of D2004 resin is temperature dependent, and the optimum catalyst level may vary according to ambient conditions and may change from day to day. Providing the addition rate is within that shown, the resin will give a satisfactory degree of cure. For intermediate levels interpolation can be used (refer to chart). The pot life for a 2kg mix /6% catalyst at 20°C will be approximately 30 to 40 minutes.

- 9.3.6 Mixing Ratio for Amcat 3 is 10% by weight of D2004 resin.
- 9.3.7 The catalysed resin is applied by brush or roller directly to the surface of the cured C50 X8. The wet film thickness should be in excess of 400 microns. The first layer of glass fibre reinforcement is then placed on the wet resin and rolled with a metal ribbed roller until the wet resin is worked through the reinforcement eliminating voids and air pockets. This process is repeated until the specified system is applied.
- The optimum resin to fibre glass ratio is 2 to 1 by weight.
- 9.3.8 The correct sequence for the fibreglass reinforcement is as follows:
- 1st Layer 450g/m² CSM
 - 2nd Layer 450g/m² Biaxial
 - 3rd Layer 450g/m² CSM
 - 4th/5th Layer 450g/m² Biaxial woven cloth (50% Overlap for final layer)
- 9.3.9 A minimum 150mm of overlap should be made when applying adjacent layers. Where it is necessary to leave a job part finished overnight (laminare terminated in a stepping method), any area to be overlapped after the D2004 has cured must be abraded using grade 80 sandpaper in order to achieve a good mechanical key for over-coating with subsequent layers of laminate.
- 9.3.10 The full system of 5 layers of laminate should be applied in one operation to avoid any sanding down.
- 9.3.11 At the termination point the laminate must be bonded directly to the painted steel substrate for a minimum of 50mm beyond the end of the foam to prevent potential water ingress. The painted substrate shall be abraded with 80 grade sandpaper to ensure good adhesion at the termination point.
- 9.3.12 The completed laminate system when cured overnight shall be abraded to remove any sharp projections and provide a good mechanical key for the D2004 flow coat.
- 9.3.13 A final flow coat of D2004 resin is applied to seal the exposed fibreglass wicks after sanding and provide a resin rich cosmetic finish.
- 9.3.14 Alternative coatings are available for applications where specific colours are required.
- 9.3.15 The D2004 laminate system must be allowed to cure for at least 24 hours at ambient temperature above 15°C before a decorative top coat is applied.

9.4 Fireproofing & Insulation termination points for Processing Vessels and Piping with the ContraFlame JF30 System.

- 9.4.1 It is a mandatory requirement that the ContraFlame JF30 Fireproofing & Insulation system is terminated in the correct manner to all stress points on Processing Vessels and Piping.
- 9.4.2 The stress points to vessels and piping are identified as nozzles, pad eyes, brackets, cleats, angle iron piping supports and vessel identification plates.
- 9.4.3 A laminate collar of 4mm (4 layers of 450gm Chopped Strand Mat) shall be applied to all nozzles, brackets, manholes, cleats and angle iron supports, extending a minimum of 150mm either side of the weld seam as a reinforcement to eliminate cracking propagation from these stress points.
- 9.4.4 The collar which will incorporate 4 layers of CSM impregnated with D2004 resin shall be applied prior to the application of the full laminate system. The full laminate system applied to the vessel shell plate should overlap 100mm onto the reinforcement collar.
- 9.4.5 After completion of the full laminate system the total thickness for the neck of nozzles, manholes, and cleats etc will be a minimum of 8mm reinforcement.

10 Repair Procedure

Repair and reinstatement of a ContraFlame® fireproofing/insulation system will be required in a number of circumstances, for example, where the original fireproofing/insulation has been damaged or where some inspection of the substrate is required. The following are instructions covering the removal of previously installed fireproofing/insulation, and preparation, repair and finishing of reinstated fireproofing/insulation.

10.1 PPE Requirements

Repair of the ContraFlame® system will involve a significant amount of grinding, and dust will result. Therefore, in accordance with General Risk Assessment and COSHH assessment the following PPE shall be worn: full or half face respirators that have a P3 dust filter. Rigger style gloves and 3M disposable coveralls (4540+) or equivalent chemical resistant coveralls shall be worn. Care should be taken to protect the skin from dust contamination and if exposure is high then it is recommend that a shower is taken along with a complete change of PPE in between work shifts.

10.2 System Removal

- 10.2.1 If D2004 Laminate has been applied to the area requiring repair then this must first be removed. Cut through the laminate layer with a disc cutter over the whole area to be repaired and chisel off the skin covering. The sound laminate surrounding the area to

be repaired must be ground down to the fibreglass matting to allow a 50mm overlap of new material to ensure a good mechanical key.

- 10.2.2 A combination of grinders, needle-guns or hand chisels can be used to remove the insulation. Care must be taken to minimise damage to the original corrosion protection coating.
- 10.2.3 The C50 X8 foam surrounding the area to be repaired should be removed with hammer and chisel, making a hole with sides sloping back away from the centre of the repair at an approximate angle of 30 to 45 degrees. The sides should not be ground smooth; it is better to chisel the old material into a series of steps or grooves which will serve to provide a good mechanical key for the new material. All surfaces must be sound and free from dust and loose material. (See diagram)

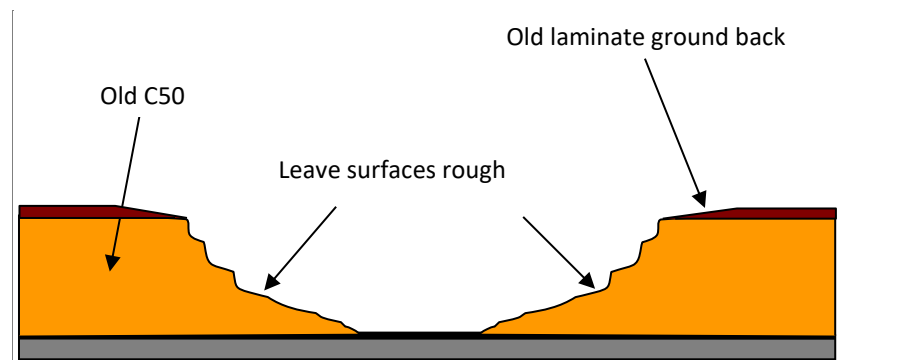

11 Reinstatement of JF30

- 11.1.1 The area to be repaired must be clean and dry and free from dust and grease.
- 11.1.2 In the event that the corrosion protection coating has been damaged, a new coating must be applied in accordance with the manufacturer's recommendations.
- 11.1.3 It is important that throughout the reinstatement process, reference be made to the individual sections of this procedure for each stage of the application, and that quality and health and safety criteria are met, ambient conditions are measured and recorded and that the stated process times for tie coat tack off, C50 X8 cure and over-coating are duly allowed.
- 11.1.4 The following sequence describes the process of replacing previously removed ContraFlame® insulation, from tie-coat application to finishing with D2004 laminate system.
- 11.1.5 Apply Tie-coat to both the exposed substrate and any existing C50 X8 around the edge of the repair zone, making sure that it is worked into all corners.

- 11.1.6 Allow Tie Coat to become tacky in accordance with procedure and then apply fresh C50 X8 up to the level of the existing material ensuring that the fresh material is worked into all edges of the repair zone.
- 11.1.7 Leave the C50 X8 foam to cure sufficiently prior to over coating with the D2004 laminate system.
- 11.1.8 Re-apply D2004 laminate system as per original application procedure, ensuring that it overlaps onto the existing laminate (where this has been ground back) by a minimum of 50mm.
- 11.1.9 Re-apply a D2004 resin flow coat to the completed laminate repair.

12 Housekeeping and Waste Disposal

12.1 Hazardous Waste

The majority of ContraFlame® raw materials are chemical products classified as Harmful or Corrosive and therefore waste which results from the application process is classified throughout the EC as “Hazardous Waste”.

The procedure for disposal of “Hazardous Waste” is different from that of general or “Controlled” waste and requires removal from site only by waste carriers licensed to do so. Items which should be treated as hazardous waste include the following:

- + Empty containers (less than 1% full) used for original supply of materials, including the plastic bags.
- + Empty containers used for de-canting, measuring or dispensing of materials.
- + Contaminated PPE, rags and paper towelling (if contaminated with solvent or uncatylsed resin).
- + Solvents or water used for cleaning of equipment.
- + Sheeting masking or protective floor covering contaminated with uncatylsed resin.

It may be that in certain circumstances the client will permit disposal of hazardous waste in their own dedicated containers, however when AI are required to remove the waste from site a licensed waste management company must be used and the transfer note must be kept for 3 years minimum.

12.2 Inert Waste

Where possible all unused and unmixed materials can be catalysed prior to disposal, with the exception of D2004 which should not be catalysed on site. Refer to procedure (QHSE31_A.7) for safe catalysing of waste. Mixed and cured ContraFlame® materials which are completely cured hard are inert so can be disposed of as general waste. This category also includes PPE, equipment, mixing containers and masking where it is certain that all the resin etc. has cured and no chemical content remains. If in doubt, treat as hazardous waste.

Controlled or non hazardous waste may be disposed of in general waste skips and arrangements should be made with the client for the use of their own site skips, or in the UK a dedicated skip should be arranged.

12.3 Waste disposal outside of the EC

Waste arising from application outside the EC will be legislated under local laws. Local laws and legislation should be adhered to.

13 Tools and Equipment

1. Paint brush (2", 4")
2. Mohair/Wool Rollers (4", 6", 9" 12")
3. Metal Rib Rollers (3", 6" & 9")
4. Plasterer's float (plastic)
5. Straight edge spatula (for scraping mixing bowl)
6. Builders Buckets
7. Plastic containers/tubs (5kg)
8. Scissors
9. Plastic Measuring dispenser (80ml)
10. Calibrated weighing scales
11. Rasp
12. Hammers and wood chisels
13. Screw in tap for 45 gal drum
14. Masking tape
15. Polythene sheets for masking
16. Sand paper (80 grit)
17. Putty/shoe knife
18. Metal scrapers
19. Portable emergency spill kit
20. Absorbent granules
21. Tapes for waste identification (Green, red, grey and blue)
22. Heavy duty waste sacks
23. Labels for general waste
24. UN rated container suitable for storing waste solvent
25. Retractable-blade/Stanley Knife

14 List of Test Equipment

QUALITY CONTROL & INSPECTION / TEST EQUIPMENT

All equipment used for testing, inspection and weighing must be calibrated in accordance with Procedure QHSE29_6 with the exception of any specified below for guidance only

AMBIENT CONDITIONS

Whirling Hygrometer

Steel Temperature Gauge

Relative Humidity & Dew Point Chart

TIE-COAT

Wet Film Thickness Gauge

C50 X8 FOAM

Metric Thickness Gauge

Flexi Hose

Thickness guide half shells

20mm diameter Thickness Inspection Ports

15 Appendices

15.1 Daily Inspection Report Form

DAILY INSPECTION REPORT



Project Name			MS 400 - System	Date	
Project Number				Report No	
Location					

ACTIVITY REPORT: Tool box talk

Report Drawing Ref	
Area Covered:	
Labour:	

PROGRESS REPORT

SUBSTRATE Corrosion Coating INSPECTION

CONDITION OF Corrosion Coating	Accepted	COMMENTS

PROGRESS REPORT

Item	Description of work/vessel I.D Location of repairs	Preparation	Tie coat/WFT	contra flex jacket	Material usage

Time	Temp - steel	C50 Part A/B	R/H	Dew Point	Materials Used	Quantities
					C50	Kits
					Tie coat	Kits
					D2004/3	KG
					Amcat	KG
					Ms 400 panel	no
					Gripfil	no

Report Drawing Ref:	Tie-Coat	C50 Part A/B Batch	D2004 Batch A/B

ENVIRONMENTAL CONDITIONS

TIME	STEEL TEMP °C	DRY AIR TEMP °C	RELATIVE HUMIDITY %	DEW POINT °C
08:00				
11:00				
13:00				
16:00				

PREPARED FOR AIS BY		SIGNED FOR CLIENT DSME	
NAME:		NAME:	
DATE:		DATE:	
SIGNATURE:		SIGNATURE:	